



**DA-8 and DA-16
Distribution Amplifiers**

CONTENTS

- INSTALLATION 3**
 - Mounting: 3
 - Connections: 3

- OPERATION 4**

- CIRCUIT DESCRIPTION 5**
 - Power Supply: 5
 - Input Stage: 5
 - Output Stages: 5

- DA-8/DA-16 PARTS LIST 6**

- DA-8 - PARTS LAYOUT 7**

- DA-8 - SCHEMATIC 8**

- DA-8/DA-16 SPECIFICATIONS 9**

- USING ACTIVE BALANCED CIRCUITRY 10**

- WARRANTY 11**
 - Repair Policy 11
 - Return Instructions 11

INSTALLATION

The Radio Systems distribution amplifier combines solid state electronics and functional flexibility in one small package. Two high quality audio op amps provide balanced output and individual gain adjustments of each channel.

Excellent isolation is provided between outputs. Each balanced channel, regardless of level set and load, is unaffected by the other channels. Audio sources can be routed to multiple locations with various level requirements and impedances while maintaining the integrity of the signal quality throughout.

The distribution amplifier is available in a single channel, 8 output mono version, or dual channel, 16 output version.

MOUNTING:

The DA-8 and DA-16 each occupy only 1-3/4 inch of height in a 19 inch rack. To allow for adequate ventilation, avoid mounting the unit directly above large heat producing equipment such as power amps or power supplies.

When stacking units, it is recommended that one rack space, (1-3/4 inch), remain open between every three units.

CONNECTIONS:

The units are primarily designed for balanced inputs and outputs. The input ground is connected to the chassis and power supply at a single point.

If unbalanced lines are used, tie the unused input terminal to ground. However, do not tie the unused output terminal to ground. Wire the output between one output terminal and the input ground terminal.

Although the outputs are short circuit protected, operating into less than a 600 ohm load is not recommended. The input is bridging (high impedance) and will not load down any source. For further details, see the section on using active balanced circuitry in this manual.

OPERATION

Controls consist of individual channel gain adjustments. Nominal operating levels are 0 dBm input and +10 dBm output. Higher operating levels can cut dynamic range by operating too close to the clipping point. Adjust each output to the desired level, keeping clipping in mind.

The input stage has a built-in 6 dB pad. This is used to increase input overload capabilities. For low level signals where additional gain is required, remove R7, which is mounted on terminal posts. See the PC layout for exact position.

To disconnect circuit (signal) ground from chassis ground, cut the jumper, marked J on the PC layout, located near the power transformer.

CIRCUIT DESCRIPTION

POWER SUPPLY:

A large circuit board mounted transformer and two, three terminal regulators provide DC power. In the DA-16, one supply is used to power both circuit boards.

INPUT STAGE:

A high speed op amp, 5534, is used as a differential pre-amp. This unit exhibits low noise and high output drive capabilities.

RFI filtering is provided by C8 and C9.

R5, R6 and R7 comprise a 6 dB pad used to raise input overload levels.

OUTPUT STAGES:

The output of IC1 feeds gain controls for each channel through a common buss. IC2, a 5534 op amp, operates at 28 dB gain. This creates one side of the output signal. IC3, another 5534, operates as a unity gain inverter to create the other side of the balanced output. This scheme almost doubles the available output voltage to create the high clipping level necessary in a distribution amplifier. The 5534 integrated circuit is utilized for its high speed, high output and low distortion capabilities.

DA-8/DA-16 PARTS LIST

All resistor values are in ohms and are $\frac{1}{4}$ W carbon film, unless noted.

T1	PC-34-700		
C1	.1 uF mylar	D1	IN4004
C2	2X1000 uF 35V	D2	IN4004
C3	2X1000 uF 35V	D3	IN4004
C4	15 uF 35V low leakage	D4	IN4004
C5	15 uF 35V low leakage	D5	LED
C8	100 pF disc	J1	Header, 3 Pin MTA
C9	100 pF disc	J2	Header, 3 Pin MTA
C10	10 uF NP 25V		
C11	10 uF NP 25V		
C12	.1 uF mylar		
C13	.1 uF mylar		
C14	.1 uF mylar		
C15	.1 uF mylar		
C16	.001 disc		
C17	.001 disc		
C18	18 pF disc		
R5	4.75K 1% MF		
R6	4.75K 1% MF		
R7	1K 5% CF		
R8	10MEG 5% CF		
R9	4.75K 1% MF		
R10	4.75K 1% MF		
R11	20K 1% MF		
R12	20K 1% MF		
R13	10K variable		
R14	4.7K 5% CF		
R15	4.7K 5% CF		
R16	39K 5% CF		
R17	10K 5% CF		
R18	10K 5% CF		
R19	10K 5% CF		
R20	100 5% CF		
R21	100 5% CF		
R22	2.2K $\frac{1}{2}$ W 5% CF		
R23	100K 5% CF		
VR1	7818		
VR2	7918		
IC1	NE5534N		
IC2	NE5534N		
IC3	NE5534N		

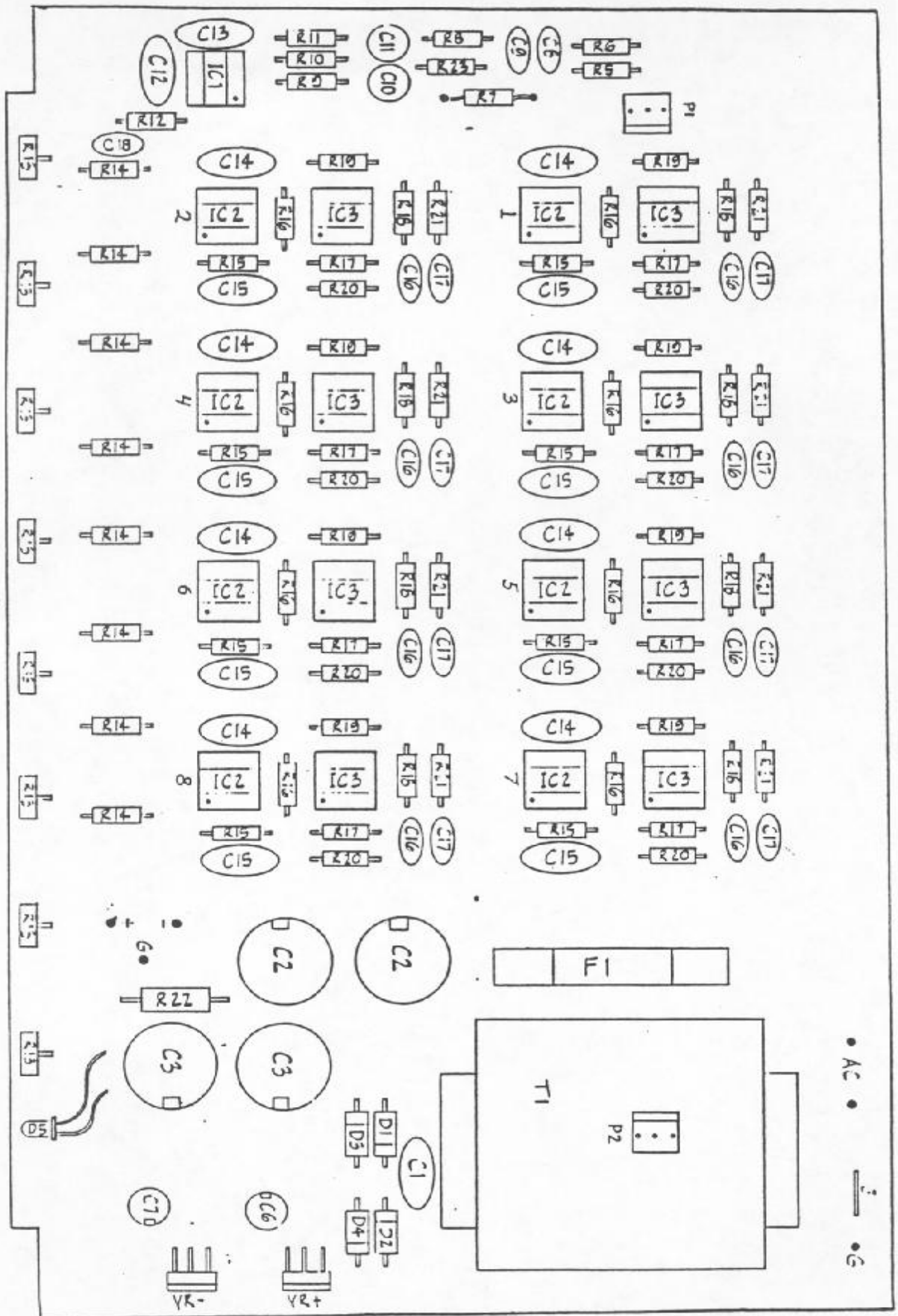

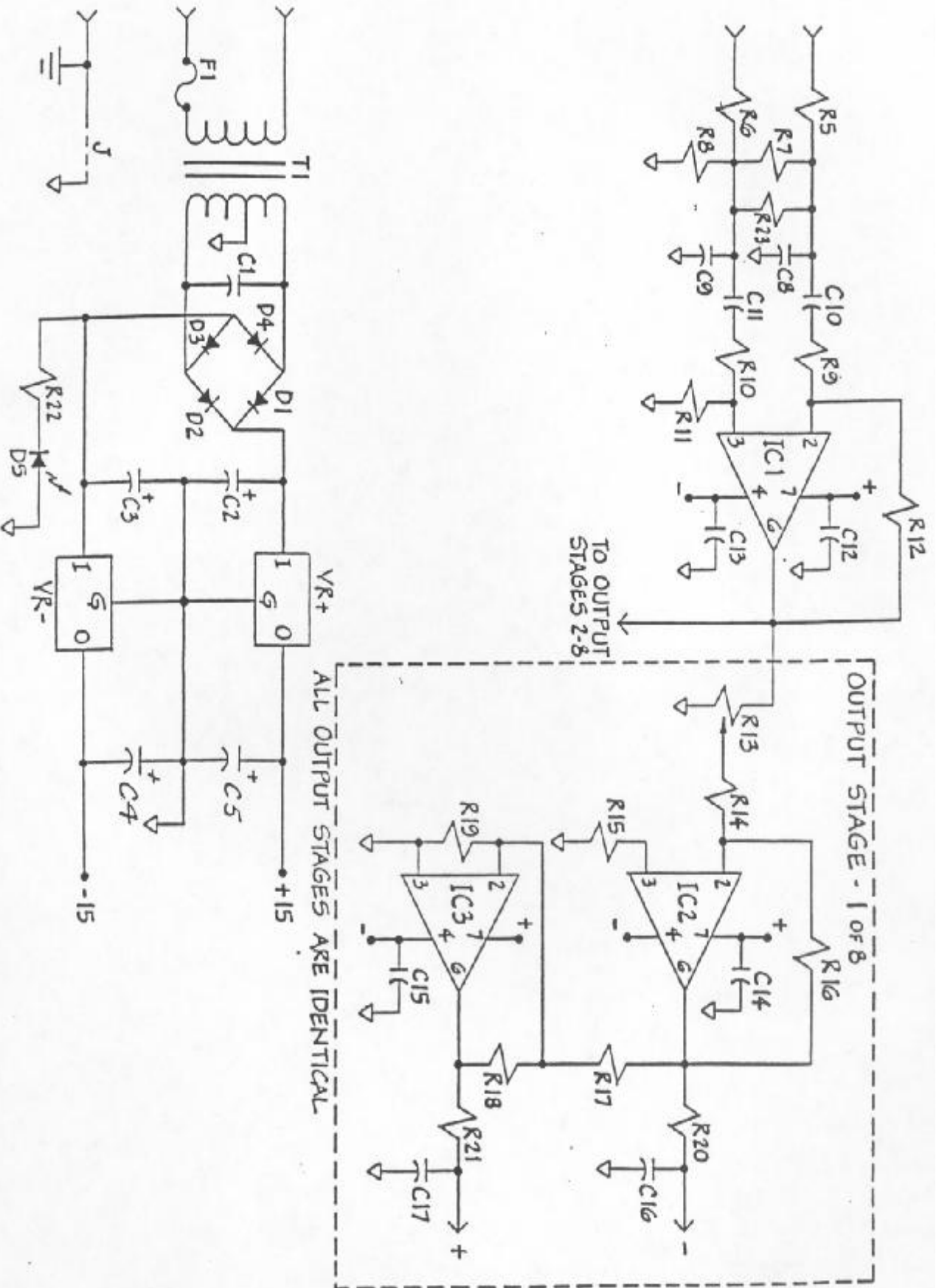

DA-8/DA-16 SPECIFICATIONS

INPUT IMPEDANCE	· 10K ohms, balanced bridging
GAIN	· 0 to +12dB, 0 to +26 dB without pad
OUTPUT LEVEL	· +25 dBm Max. into 600 ohms
OUTPUT IMPEDANCE	· 200 ohms, balanced
FREQUENCY RESPONSE	· +.1dB 20Hz to 20kHz
THD @ +18 dBm	· .01% max. 20 Hz to 20 kHz
SMPTE IM @+18dBm	· .01% max.
MAXIMUM INPUT LEVEL	· +26 dBm, +14 dBm without pad
COMMON MODE REJECTION	· 60 dB @ 60Hz min.
NOISE	· Min. 90dB relative OdB input
SLEW RATE	· 13V/micro sec.
OUTPUT CHANNEL ISOLATION	· > 90 dB
DIMENSIONS	· 19" rack mount 1 ³ / ₄ " high 6" deep

USING ACTIVE BALANCED CIRCUITRY

Balanced lines have been used for many years and are in continued use today because of their immunity to stray pickup. Induced signals appear on both sides of the balanced line. The receiving end of the balanced line responds only to the difference voltage between the lines which is the desired signal. Induced signals are common to both and are balanced out.

Transformers have been the mainstay of balanced circuitry for decades. Unfortunately, transformers cause distortion and ringing, and are susceptible to magnetic flux pickup. Further, good quality audio transformers are very expensive.

The use of op-amp balanced circuitry has the advantages of transformers without the disadvantages. The only caveat is that careful wiring practices are more important with active balanced than with transformers.

Active balanced outputs and inputs use three wires: +, -, and ground. The + and - terminals are both driven and neither should ever be connected to ground. For best performance, a three-conductor shielded wire should be used. The third wire completes the ground circuit. The shield should be connected to the ground at one end of the wire only. If a two-wire shielded cable is used, it is important that a ground connection be made between the sending and receiving units. A ground circuit through equipment chassis or through three-prong AC cord ground is also acceptable.

Single-ended audio interconnections lack the interference immunity of balanced hookups. For that reason, keep unbalanced connections short, direct, and well separated from AC power wires. To drive a single-ended load from an active balanced source, use coaxial wire: + to center conductor and ground to shield, leaving the - output unconnected. To feed an active balanced input from a single-ended source, use coaxial wire, connecting the hot center conductor to +. Connect the shield to ground and put a jumper from ground to -.

When driving an active balanced input from a transformer balanced floating source, use two conductor shielded wire. Ground the shield at the source end. Establish good ground between the chassis either directly or through AC plug ground prongs. At the load, connect the + lead to the + input and the - lead to the - input. Put two 300 ohm resistors in series between the + input and the - input and connect their mid-point to the load ground. This correctly terminates the source output transformer for optimum frequency and transient response (freedom from ringing) and provides a low impedance return path for leakage and induced hum. If more than one active balanced load is to be placed across a floating balanced transformer source, install this resistive termination once only. From that location to the active balanced loads, run three-conductor shielded wire, shield continued from the source chassis, + from +, - from -, and ground from the mid-point of the terminating resistors.

To drive a balanced floating transformer load from an active balanced source, use shielded wire. Connect the shield to source ground and leave the shield open at the load end. Connect + to + and - to -, and establish a good source ground to load chassis connection, either through a third wire in the interconnect cable or through chassis contact or AC cord third wire ground.

Interconnections between pieces of stereo equipment require doubling the connections described above without duplicating the ground connection. Between pieces of active balanced stereo equipment, then, 5 shielded conductors should be run.

When testing active balanced equipment with single ended test equipment, do not connect the - to test equipment ground. Most modern test equipment provides balanced inputs. In many dual-trace oscilloscopes, balanced signals may be displayed by running the two inputs in the "add" mode with one input switched to invert. To perform a test with single-ended equipment, + and - outputs must be tested independently and their results added. Testing only a single output results in a 6 db loss in output level.

The active balanced equipment interconnection format makes possible state of the art fidelity. Careful attention to detail and conservative practice will be rewarded with outstanding flat frequency response, low distortion, and wide dynamic range.

WARRANTY

Radio Systems, Inc., warrants this equipment to be free from defects in materials and workmanship for a period of one (1) year after purchase.

This warranty extends to first users of the product and future owners who purchase the product within the warranty period.

The terms of this warranty are null and void if this product is stored or operated in an environment not conducive to electronic equipment, or shows signs of misuse or modifications which affect the proper functioning of the product. This warranty does not apply to damage caused by fire, smoke, flood, lightning, or acts of nature and physical abuse.

Radio Systems, Inc., and its associated companies, authorized distributors, and personnel are not liable for loss of revenues or other damages, or effects to the broadcast signal quality or coverage which may result from the improper functioning of this product.

REPAIR POLICY

Technical assistance is available at any time, at no charge, by phone or correspondence.

During the warranty period, there will be no charge for parts or service made to units which show no sign of misuse by customer or lightning caused damage. The customer is responsible for the cost of shipping their unit back to Radio Systems for repair. During the warranty period, shipment of small parts and assemblies will be made at no charge to the user. Emergency, next day shipments of replacement parts and circuits will also be made at no charge at the user's request. Chargeable services will be made COD or on Net-30 day terms to users with established accounts.

During the warranty period, users must return defective parts upon request to receive no-charge warranty services. Return shipping expenses are the responsibility of the user.

RETURN INSTRUCTIONS

Contact Radio Systems at +1-856-467-8000 for a return authorization number.

Pack all items carefully and ship prepaid, via UPS insured, to:

Radio Systems, Inc.
Attn: R.A. # _____
601 Heron Drive
Logan Township, NJ 08085

Enclose a note which includes your name, company, phone number, the serial number, return address (no box numbers), and a complete description of the problem.

Rev : 09/2003



601 Heron Drive
Logan Township, NJ 08085
Phone: 856-467-8000
Fax: 856-467-3044
<http://www.radiosystems.com>