

Technical Bulletin

No: 114 – Dual Phone Hybrid Mix-Minus Card

Installation

Your new console includes a special mix-minus circuit installed at the factory. This circuit is provided via a modified distribution amplifier card, mounted inside the console at the factory

All required connections between the internal card and the console were wired prior to shipping. The user must connect the card's outputs to the studio's two phone hybrids.

Following the attached diagram, connect "Output A Left" on the card to the input of Hybrid 2, and "Output B Left" to the input of Hybrid 1.

Wire the output of Hybrid 1 to the console's normal input for Channel 11-B, and wire the output of Hybrid 2 to the console's normal input for Channel 12-B. (Refer to the hybrid manual and console manual for wiring instructions.)

Setup

Set the level of the mono fix feeding Hybrid 1 by adjusting pot "B-left" on the internal card (see attached diagram). Set the level of the mix feeding Hybrid 2 by adjusting pot "A-Left".

Set the level of the Caller 1 audio feeding Hybrid 2 by adjusting pot "C-left", and set the level of Caller 2 audio feeding Hybrid 1 by adjusting pot "C-right".

Set the hybrid nulls and other adjustments following the manufacturer's directions.

Operation

The internal card will automatically feed audio from Caller 1 to Caller 2 and vice-versa.

To allow the caller to hear any other audio sources (including jock mic), depress the console's mono switch for that source.

TO put the callers on the air, depress the console's program buss switch for that caller (Caller 1 on Input 11-B, and Caller 2 on Input 12-B) and set the channel pot level as usual.

Do NOT depress the mono buss switch of either phone channel.



601 Heron Drive
Logan Township, NJ 08085
Phone: 856-467-8000 • Fax: 856-467-3044
<http://www.radiosystems.com>

Technical Bulletin

No: 114 – Dual Phone Hybrid Mix-Minus Card

Description

This compact circuit card installs internally in RS Series consoles and may be connected to any audio output(s) to distribute signal to multiple sources. The card features bridging inputs, low impedance outputs, and independent level adjusts for each output.

Installation

Use the plastic pins supplied to mount the circuit card on any free slot on the console inside rear wall. Supply DC power via the three wire cable from the auxiliary DC output connector (J15) on any sk channel input board.

Applications

Use the DA to distribute program audio, or to create a mono program blend by paralleling left and right outputs. The DA may also be wired to loop thru channel patch points (while leaving the loop-thru jumpers in place) to "pick off" and distribute individual channel audio. The DA, used in this application, will balance and buffer the audio, maintaining the integrity of channel audio as it exits the console.

Configurations

Stereo 2 x 2	Two stereo inputs each feeding two stereo outputs
Stereo 1 x 4	One stereo input feeding four stereo outputs
Dual 2 x 4	Two mono signals each feeding four mono outputs
Quad 4 x 2	Four mono signals each feeding 2 mono outputs
Mono 1 x 8	One mono signal feeding 8 mono outputs

Wiring

To achieve these configurations, simply wire the input audio across the appropriate single or multiple audio input terminals.

Because inputs are all balanced high impedance bridging, audio can be multiple terminated without adverse sonic effects.

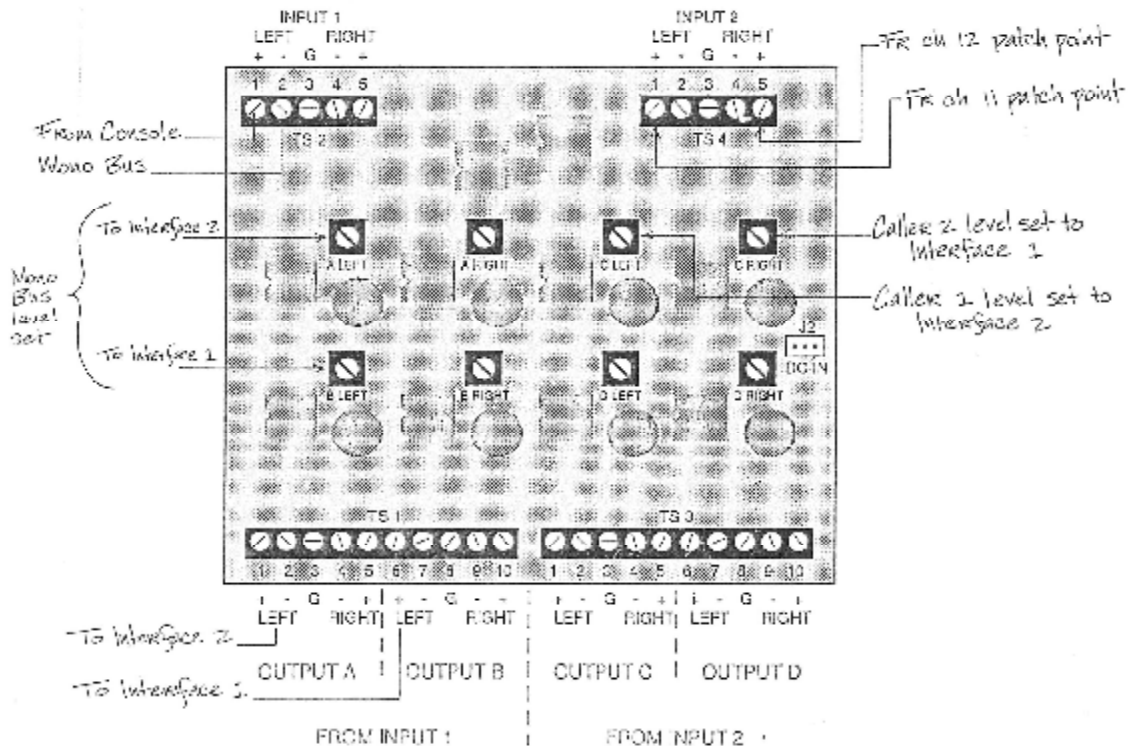

601 Heron Drive
 Logan Township, NJ 08085
 Phone: 856-467-8000 • Fax: 856-467-3044
<http://www.radiosystems.com>

Technical Bulletin

No: 114 – Dual Phone Hybrid Mix-Minus Card

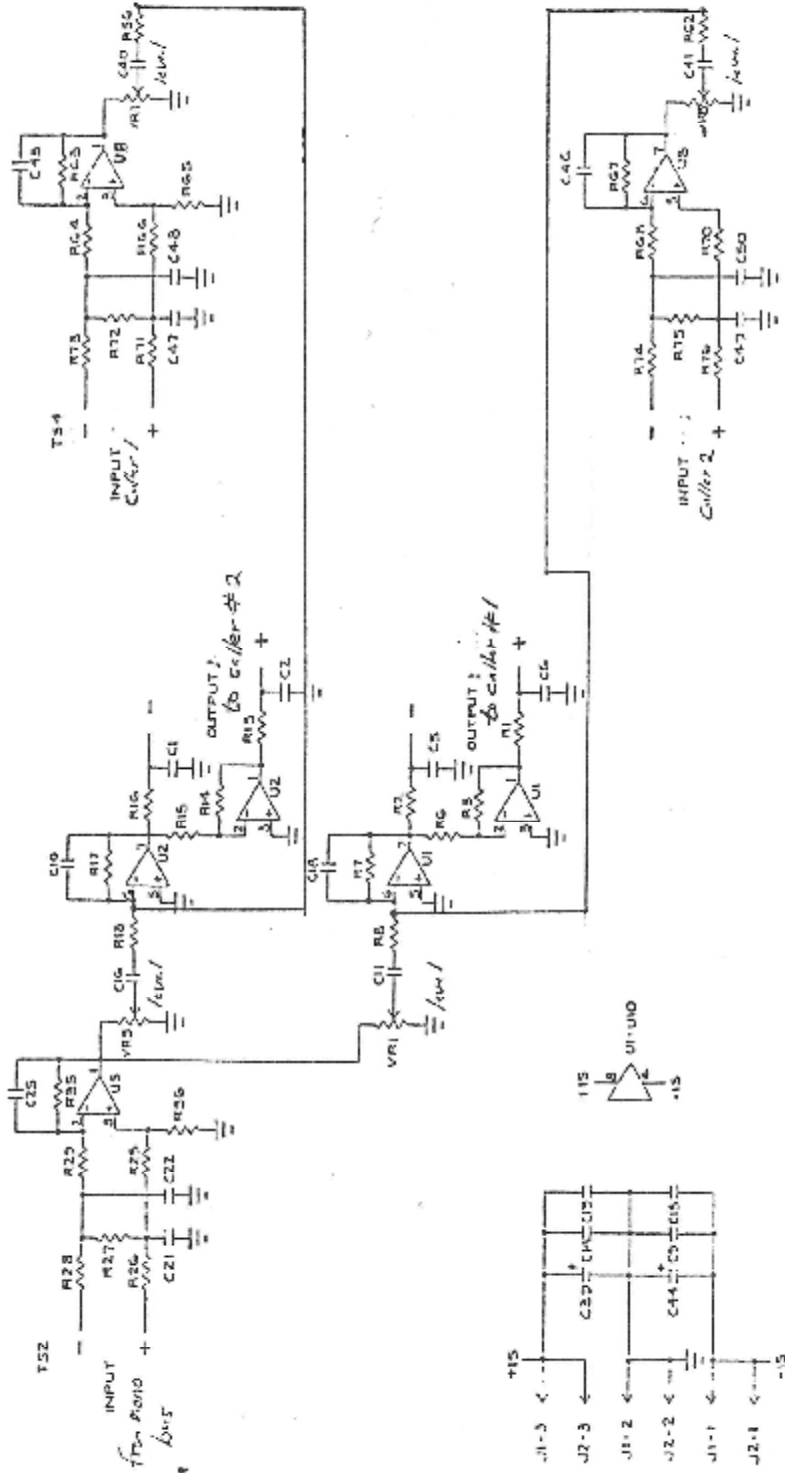

Title: <i>London Phone-Minus Mixer</i>		
Type: SCHEMATIC		
Size: Code: Part #: 7706		
Sheet: Rev. #: Sheet 1 of 1		
RADIO SYSTEMS INC Englewood, Pa., U.S.A.	Product: R.S. SERIES CONSOLE	
This document and the information herein is provided in confidence for the use of Radio Systems employees and those their advisors, transfer, or use for any reason, in whole or in part, is expressly prohibited without the prior written permission of Radio Systems, Inc.		